

Thermoelectric module TM - 63-1.0-3.0



Performance Data

I _{max} (amps)	3.3	$\Delta T = \Delta T_{max}$. Th=25 ± 0.5 °C.
V _{max} (volts)	7	Th=25 ± 0.5 °C. $\Delta T = \Delta T_{max}$. I=I _{max} ± 0.1A
ΔT_{max} (°C)	71	Th=25 ± 0.5 °C. I=I _{max} ± 0.1A
Q _{max} (watts)	14.7	Th=T _c =25 ± 0.5 °C. I=I _{max} ± 0.1A
AC resistance (ohms)	1.9	25 ± 0.5 °C.

Environment: dry air, N₂

Tolerances for thermal and electrical parameters ± 10%

Drawing № ND 052.00.00

Dimensions in millimeters

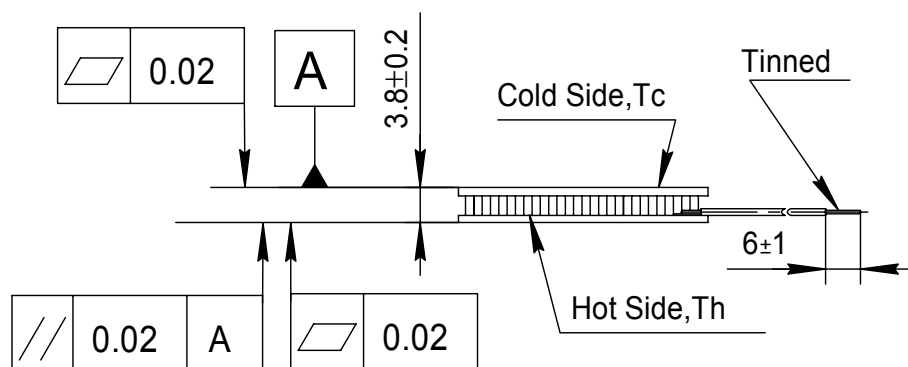

Options

Model Number	Description
TM-63-1.0-3.0 M	High reliable version on Cold Side

Lead wire insulation	Module maximum processing temperature
PVC	90°C
Silicone	200°C
PTFE	200°C

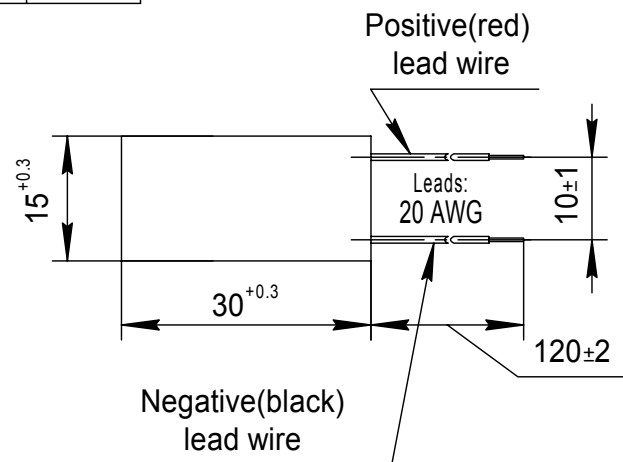

Additional

- RoHS 2002/95/EC compliant
- Cold Side and Hot Side Ceramics: Al₂O₃, white 96%
- Assembling Solder: SnSb, M.P. 232 °C ; SnCu M.P. 227 °C

Performance graphs for TM-63-1.0-3.0 modules at $T_h=25\text{ }^\circ\text{C}$
 Environment: dry air, N_2

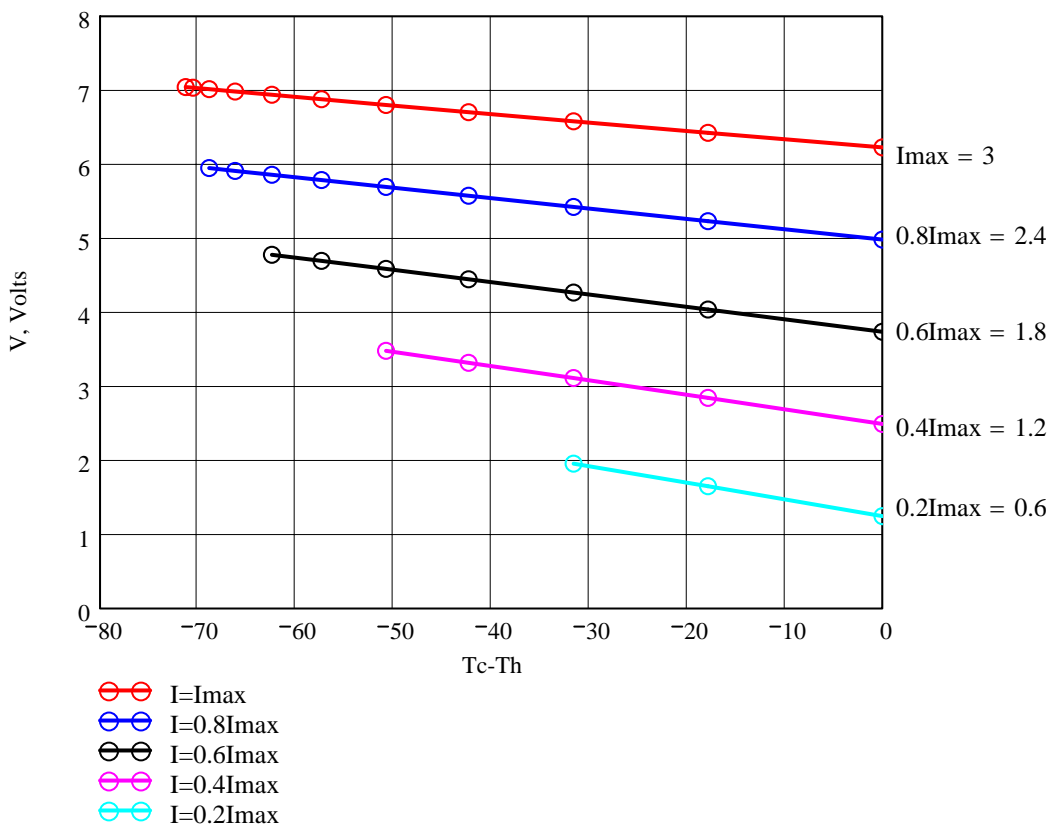
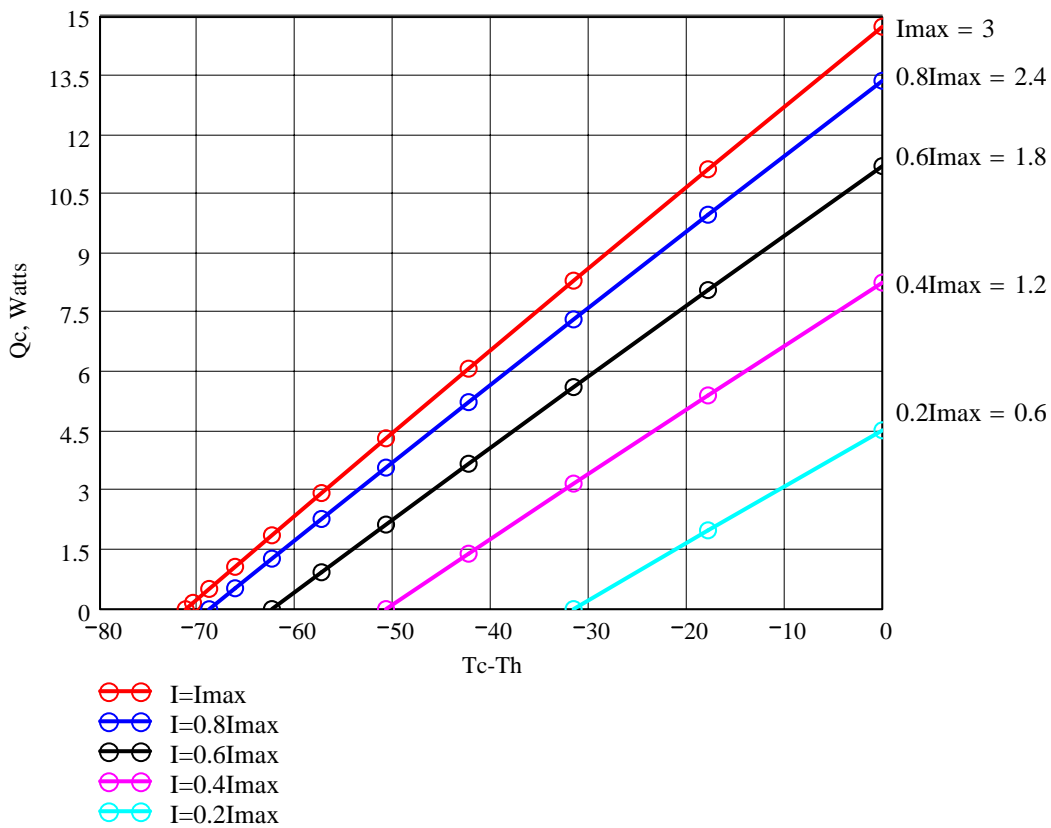

Q_c - refrigerating capacity at cold side of the module (Watts),
 $\Delta T = T_c - T_h$ - temperature difference between cold and hot sides of the module (°C),
 I - DC current through the modules (Amps)
 V - voltage applied to the module (Volts).

Performance graphs for TM-63-1.0-3.0 modules at $T_h=50\text{ }^\circ\text{C}$
 Environment: dry air, N_2

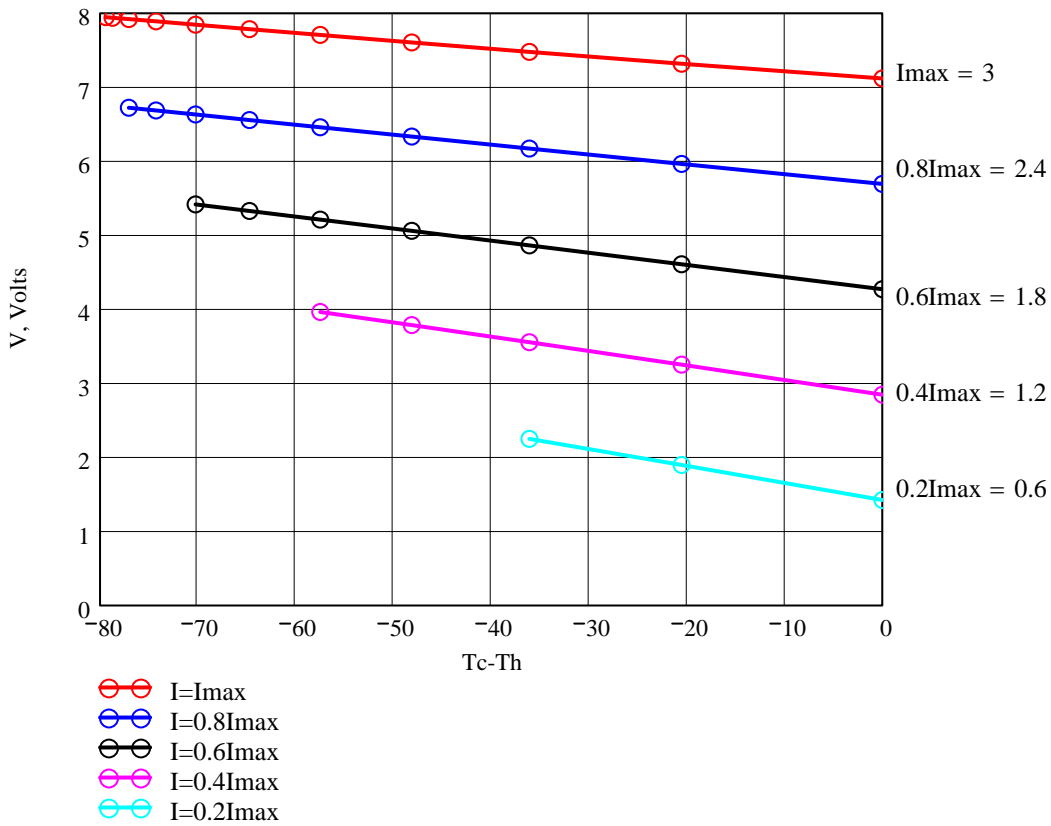
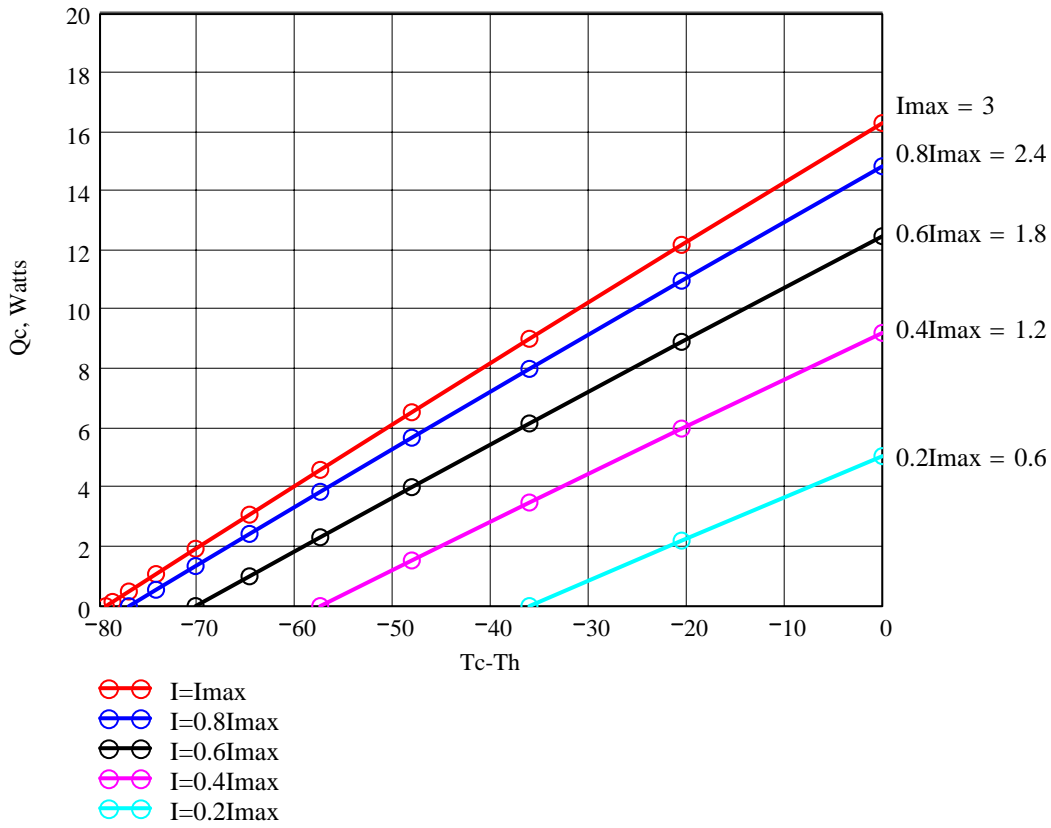

Q_c -refrigerating capacity at cold side of the module (Watts),
 $\Delta T = T_c - T_h$ - temperature difference between cold and hot sides of the module (°C),
 I - DC current through the modules (Amps)
 V -voltage applied to the module (Volts).