

Thermoelectric module TM - 63-1.4-3.7



Performance Data

I_{max} (amps)	4	$\Delta T = \Delta T_{max}$. $T_h = 25 \pm 0.5$ °C.
V_{max} (volts)	7.3	$T_h = 25 \pm 0.5$ °C. $\Delta T = \Delta T_{max}$. $I = I_{max} \pm 0.1A$
ΔT_{max} (°C)	71	$T_h = 25 \pm 0.5$ °C. $I = I_{max} \pm 0.1A$
Q_{max} (watts)	17.3	$T_h = T_c = 25 \pm 0.5$ °C. $I = I_{max} \pm 0.1A$
AC resistance (ohms)	1.6	25 ± 0.5 °C.

Environment: dry air, N_2

Tolerances for thermal and electrical parameters $\pm 10\%$

Drawing № ND 053.00.00

Dimensions in millimeters

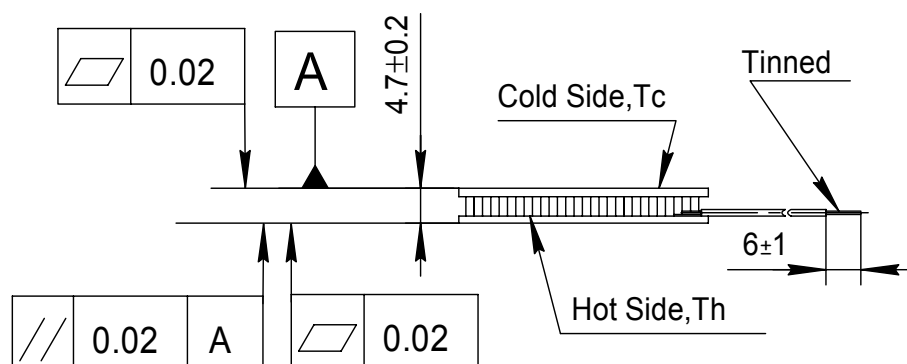

Options

Model Number	Description
TM-63-1.4-3.7 M	High reliable version on Cold Side

Lead wire insulation	Module maximum processing temperature
PVC	90°C
Silicone	200°C
PTFE	200°C

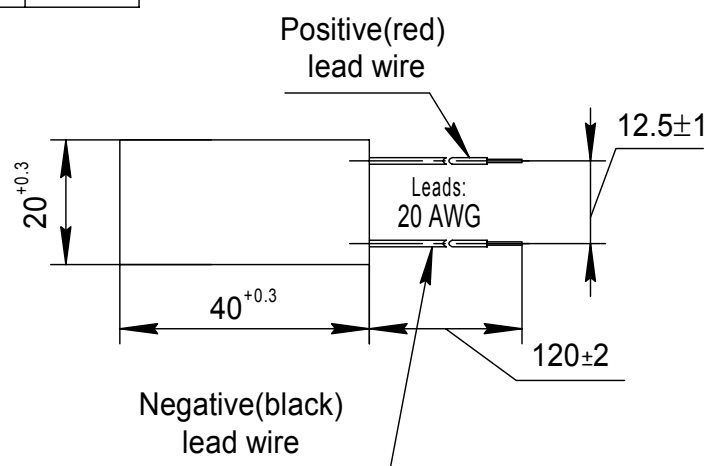

Additional

- RoHS 2002/95/EC compliant
- Cold Side and Hot Side Ceramics: Al₂O₃, white 96%
- Assembling Solder: SnSb, M.P. 232 °C ; SnCu M.P. 227 °C

Performance graphs for TM-63-1.4-3.7 modules at $T_h=25\text{ }^\circ\text{C}$
 Environment: dry air, N_2

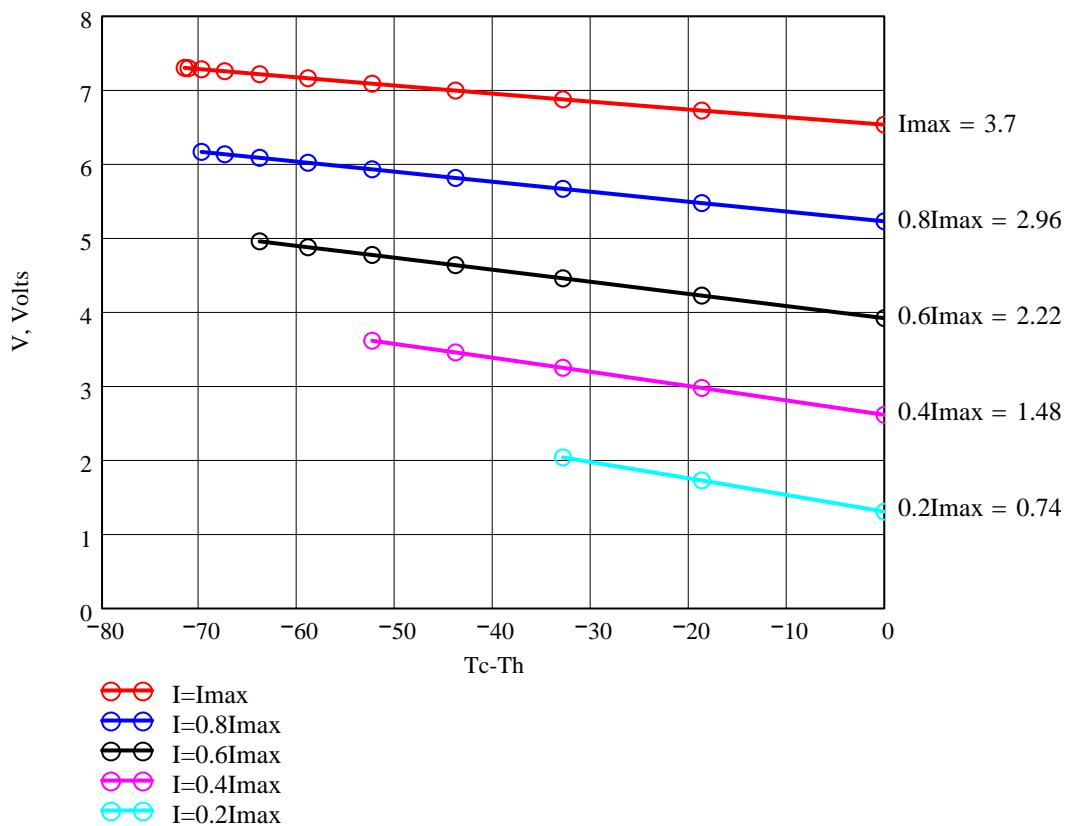
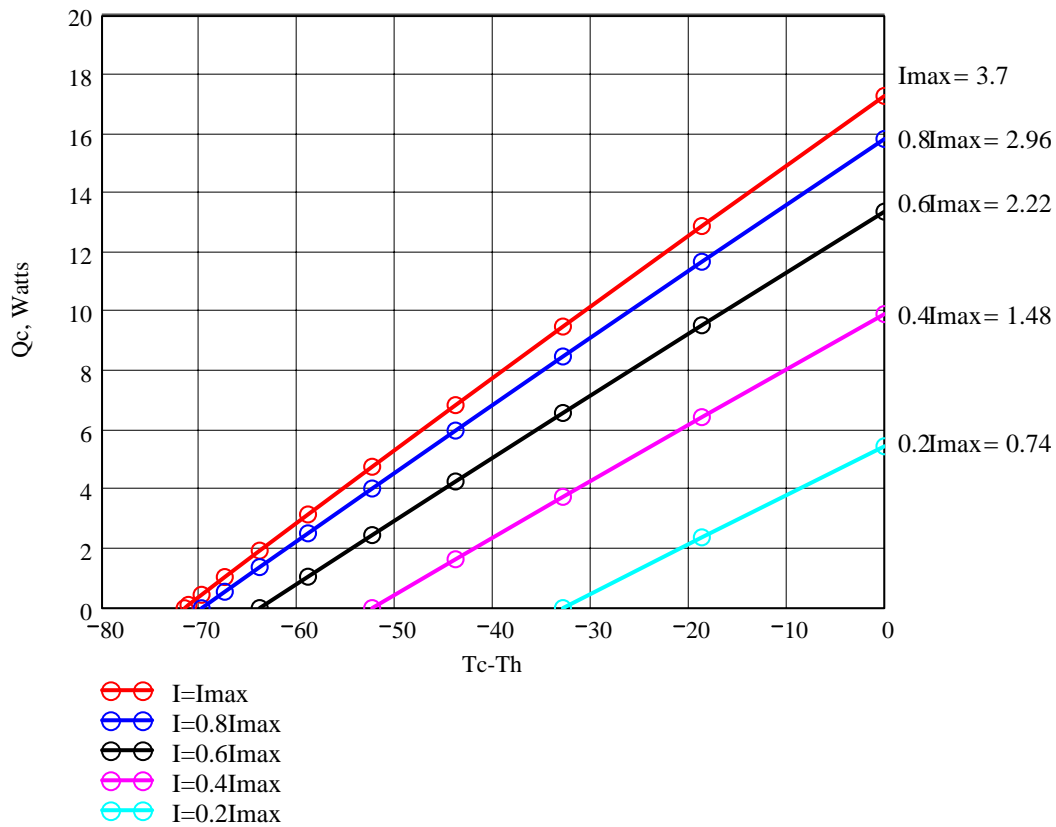

Q_c -refrigerating capacity at cold side of the module (Watts),
 $\Delta T = T_c - T_h$ - temperature difference between cold and hot sides of the module ($^\circ\text{C}$),
 I - DC current through the modules (Amps)
 V -voltage applied to the module (Volts).

Performance graphs for TM-63-1.4-3.7 modules at $T_h=50\text{ }^\circ\text{C}$
 Environment: dry air, N_2

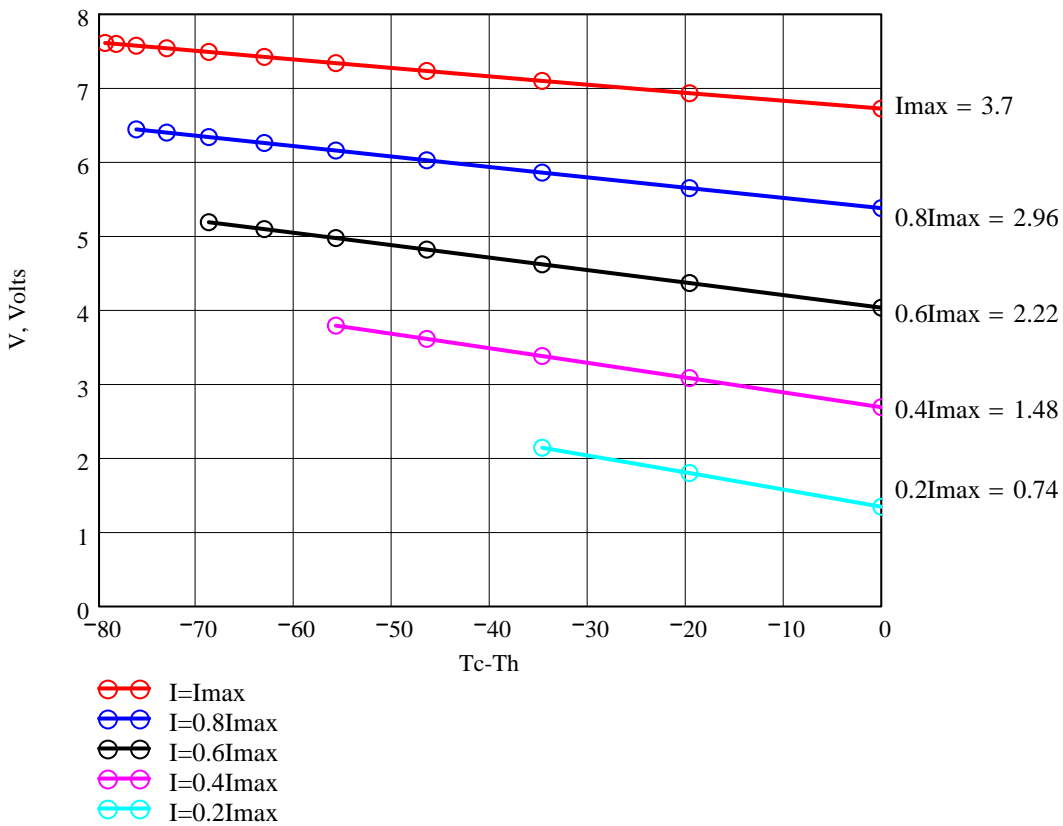
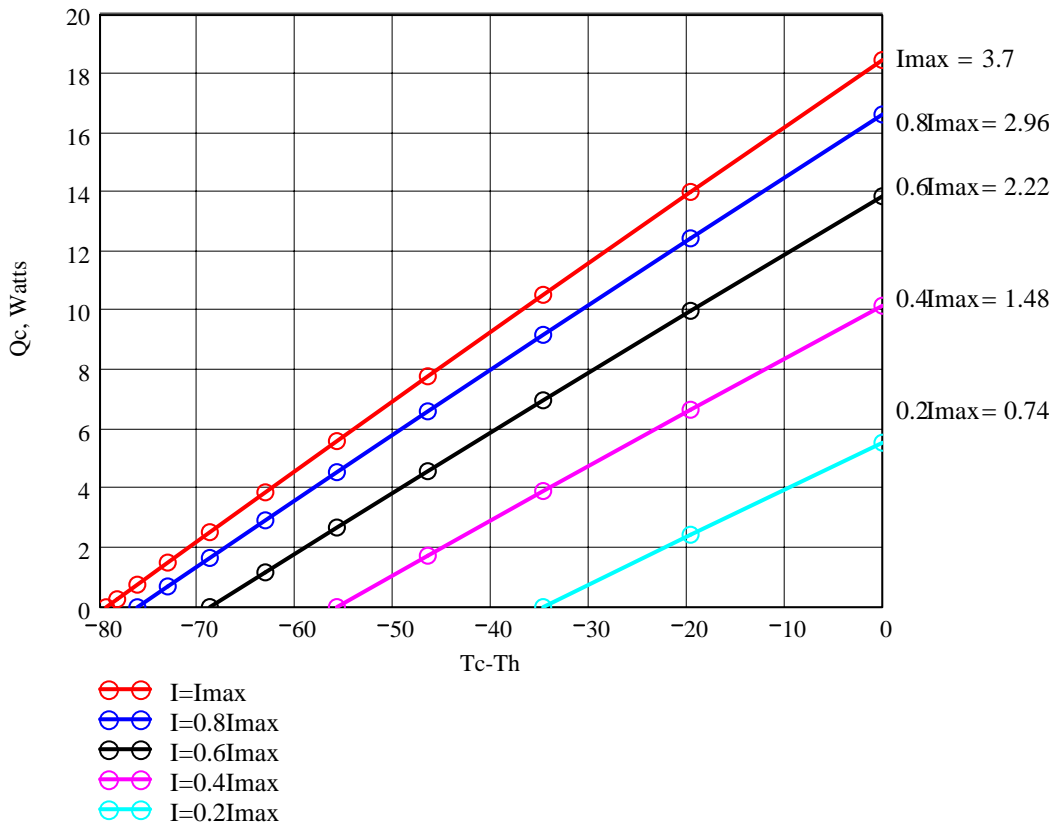

Q_c -refrigerating capacity at cold side of the module (Watts),
 $\Delta T = T_c - T_h$ - temperature difference between cold and hot sides of the module (°C),
 I - DC current through the modules (Amps)
 V -voltage applied to the module (Volts).